

Figure 1

INTRODUCTION

This instruction sheet covers the assembly procedures for LEPRA/CON Slide-On Series Straight Plugs and Jacks. See Figure 1.

NOTE Dimensions on this sheet are in inches [with millimeters in brackets]. Figures and illustrations are for identification only and are not drawn to scale.

Step 1

Slide the crimp sleeve over the jacket. Strip cable to dimensions shown in Figure 2.

CAUTION Be careful not to nick inner conductor or shield.

Note: For assembly to cables with “Mini-Noise” coating, Mini-Noise coating must be removed from surface of cable dielectric as follows:

1. Painted Coatings: Wipe off dielectric surface with a dry cloth. Wipe again using paint thinner or trichloroethane. Do not immerse cable in solvent.

2. Tape or Fused Coatings: Remove with sandpaper, file, or scraping action of razor blade. Do not damage dielectric.

DANGER To prevent personal injury, use caution when handling file or razor blade.

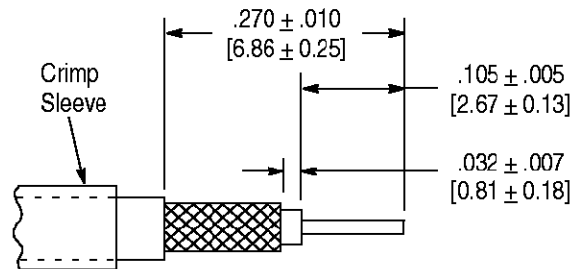

NOTE: Not to Scale

Figure 2

Step 2

Slide back the end of the contact subassembly between the shield and dielectric. Inner conductor must be visible through inspection hole. Refer to Figure 3.

Crimp contact to inner conductor using Tyco Electronics Tool Number 4-1532136-0 (Microdot Tool Number 010-0150-0000) or Astro Tool Number 826D■ for plug or straight jack.

Use Tyco Electronics Tool Number 8-1532137-4 (Microdot Tool Number 010-0161-0000) or Davo Tool Number 827 for crimping bulkhead jack pin contact.

Slide crimp sleeve over shield and against contact subassembly.

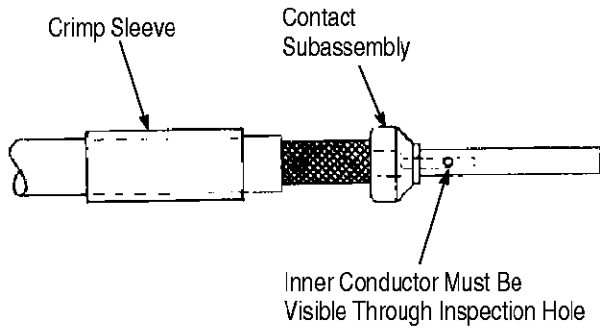

Figure 3

Step 3

Slide the assembled parts into the housing subassembly. Make sure the crimp sleeve is in place.

Crimp rear of housing using Tyco Electronics Tool Number 3-1532136-8 (Microdot Tool Number 010-0132-0000) or Thomas & Betts™ Tool Number WT-419●. Refer to Figure 4.

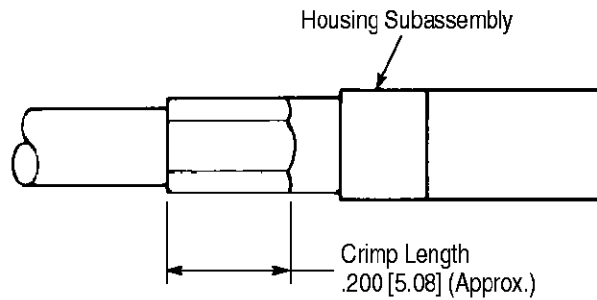

Figure 4

Step 4

Note: Bulkhead Jack only

Insert connector through hole in panel. Refer to Figure 5 for hole size. Secure with lockwasher and nut (not shown).

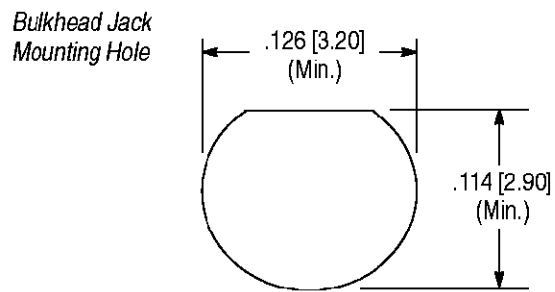

Figure 5

REVISION SUMMARY

Per EC 0990-0808-01

- Initial release of instruction sheet

■ Product of Astro Tool Corp.
● Consult manufacturer's literature for current information.